

**AB** **TECHNICAL**  
**O3** **SPECIFICATION**

**Electrical**

Input voltage: 240V AC single phase 50Hz  
 Rated power: 1600 W  
 Motor type: Dyson digital motor. Switched reluctance brushless  
 Heater type: None  
 Standby power consumption: 1 W  
 Energy consumption per dry: 0.0044 kWh

**Construction**

Polycarbonate-ABS casing with homogenous anti-microbial additive in all external surfaces  
 Colour finish: Grey or White  
 Light reflective value: 28.3 (grey); 77.4 (white)  
 Anti-microbially impregnated external plastics and seals  
 Galvanised steel back plate / mounting bracket  
 Tamper-proof T30 type exterior screws  
 Water ingress protection to IPX5

**Filter**

Anti-microbial HEPA filter  
 Bacteria removal 99.9%

**Operation**

Touch-free infra-red activation  
 Hand dry time: 10 seconds (measured to method defined by National Sanitation Foundation protocol P.335)  
 Operation lock-out period: 30 seconds  
 Airspeed at apertures: 400 mph  
 Operating airflow: 35 l/s  
 Rated operating noise power (max): 85 dB(A)

**Logistics**

Serial number prefix: A03 (grey); AA5 (white)  
 Single unit order code: 14977-01 (grey); 19799-01 (white)  
 Net weight: 10 kg  
 Packaged weight: 13 kg  
 Packaged dimensions: 728 x 358 x 302 mm (+/- 6mm)  
 Pallet count: 13  
 Pallet type: UK (1200 x 1000 mm)  
 Unit barcode: 5025155007853 (grey); 5021555009833 (white)

**Warranty**

Parts and labour breakdown warranty from Utility Rentals for the rental duration.

**Product Certification**

BEAB approved to IEC/EN60335-1 and IEC/EN60335-2-23 Compliant to EMC directive according to EN55014-1, EN55014-2, EN61000-3-2, EN61000-3-

Recommended installation heights measured from floor	Male	Female	Child or Disabled
x To top of machine	1050 mm	975 mm	900 mm
y To mounting bracket screw	990 mm	915 mm	840 mm
z to bottom of machine	387 mm	312 mm	240 mm

Minimum: 200mm from floor; 50mm clearance either side and above machine

REAR ELEVATION

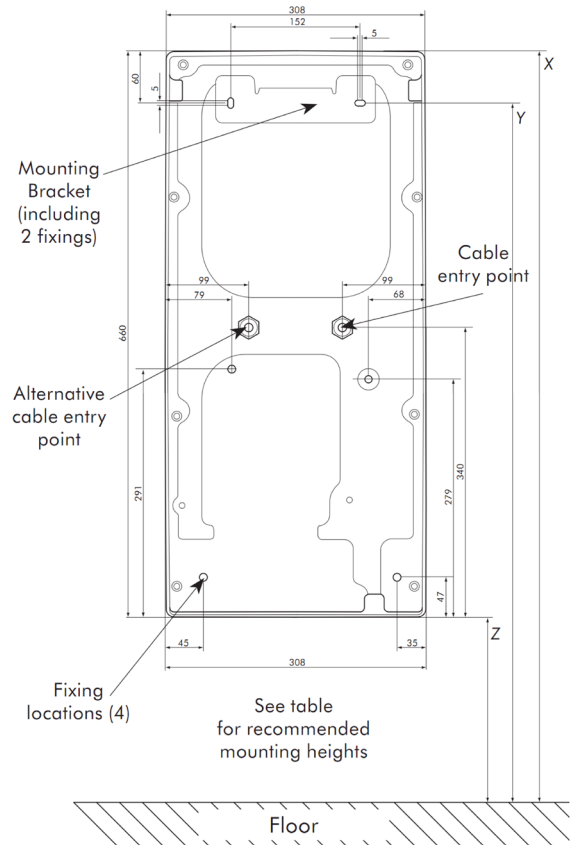

SIDE ELEVATION

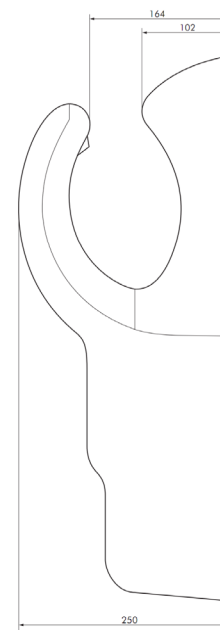

All dimensions shown in mm (+/-5mm)

The NSF logo is a registered trade mark of NSF International. The handprint logo is a registered trade mark of the British Skin Foundation.

